

Ever-Power Transmission Group Co. Ltd.



SYF-1 Series

Center-dive Worm Gear Box

Model Numbers:

SYF-1-20=87rpm(20:1 ratio)

SYF-1-30=58rpm(30:1 ratio)

SYF-1-40=43rpm(40:1 ratio)

SYF-1-50=35rpm(50:1 ratio)

SYF-1-58=30rpm(58:1 ratio)

SYF-1-60=29rpm(60:1 ratio)

(When input speed is 1740 rpm)



Introduction:

This type of worm gear box has been widely used on the driveline (drive train) of the center pivot irrigation system and the linear move (later move) irrigation system on North America, European area and Middle East. It employs aluminum alloy case and major transmission parts are made from high strength alloy. By use of large number sealing and dust-proof devices it features light in weight, long service life and good tightness as well.

Performance:

1. Torque capacity: 4,500 lb.in (510 N.m).
2. Ratio: 20:1, 30:1, 40:1, 50:1, 58:1, 60:1 (others available).
3. Accepts NEMA 56-C face motors with 0.625" shafts, 2" long with 0.19" key slot.
4. Multiple mount bolt patterns 5"×6", 3.38" ×6.38" fit all pivots.
5. High strength aluminum bronze worm gear.
6. Includes easy installing shock absorbing motor to worm gear box coupler.
7. Both output shafts have 1/4" ×1-1/4" keyways.
8. Shipped with oil.
9. Includes special external crop guard seals.
10. Precision die cast tempered aluminum housing.
11. Weight: 15.9 lbs (7.2Kg).
12. Oil capacity: 0.21 gal (0.8 L)

SYF-1 Series

Center-drive Worm Gear Box

Installation and contour dimension (dimensions are in inch):

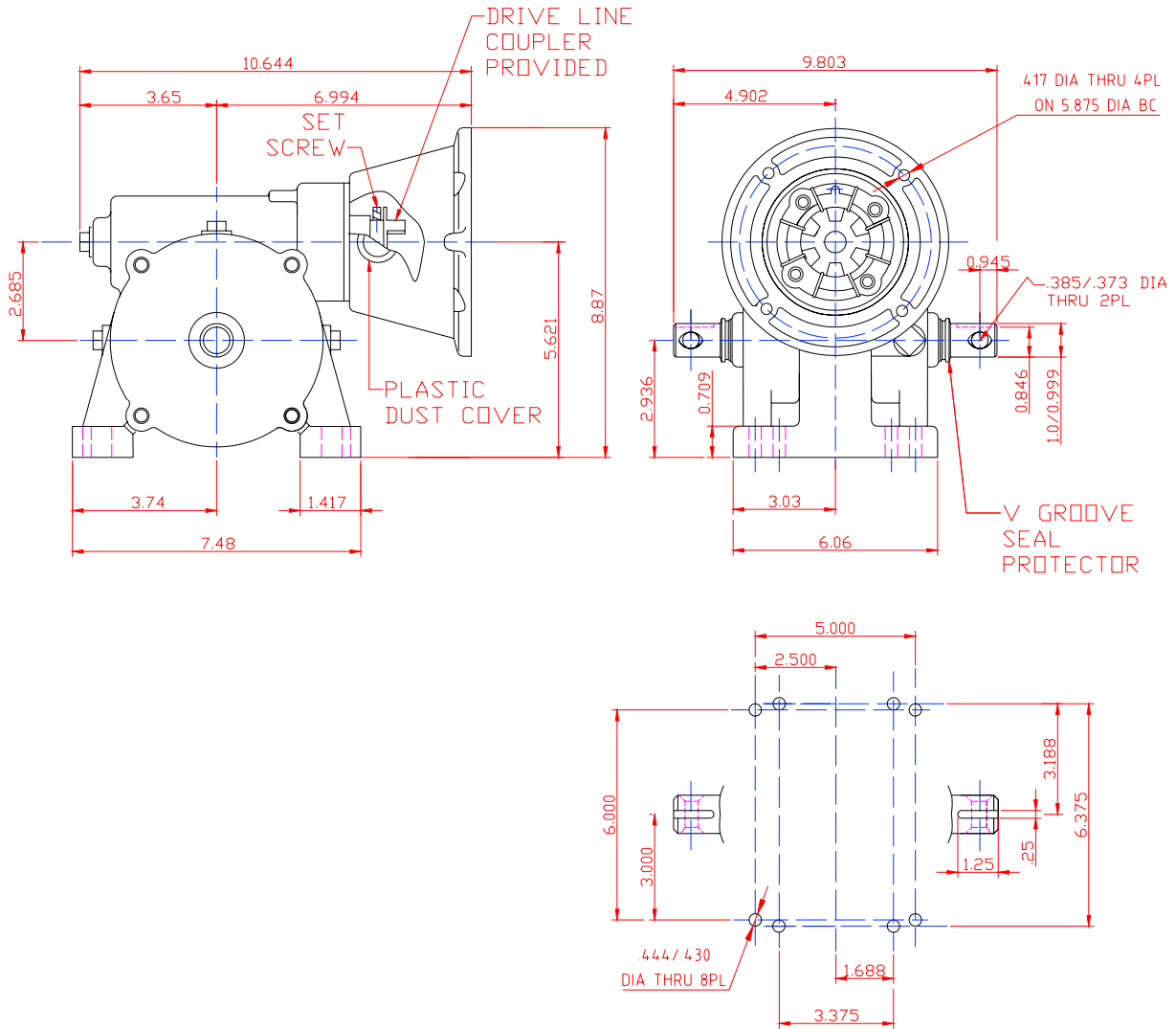

EVER-POWER TRANSMISSION CO., LTD.

SYF-2M Series

Center-drive Worm Gear Motor

Model Numbers:

SYF-2M-20=87rpm(20:1 ratio,1-1/2 HP motor)

SYF-2M-30=58rpm(30:1 ratio, 1-1/2 HP motor)

SYF-2M-40=43rpm(40:1 ratio, 1 HP motor)

SYF-2M-50=35rpm(50:1 ratio, 1 HP motor)

SYF-2M-58=30rpm(58:1 ratio, 1 HP motor)

SYF-2M-60=29rpm(60:1 ratio, 1 HP motor)

(When input speed is 1740 rpm)



Performance:

1. Ratio: 20:1, 30:1, 40:1, 50:1, 58:1, 60:1 (others available).
2. Use self-locking taper shaft connection (motor to worm-shaft) allows on-site replacement without removing worm-shaft, or disconnecting the load. This ensures precision alignment eliminates fretting to expedite motor removal.
3. Mount bolt patterns 5" × 6".
4. High strength aluminum bronze worm gear.
5. Shipped with oil.
6. Includes special external crop guard seals.
7. Precision die cast tempered aluminum housing.
8. All critical electrical connections are encapsulated to resist penetration of moisture.
9. Specially designed for rugged irrigation duty.
10. 460/380 volt, 3 phase, 60/50 HZ dual voltage.
11. Thermally protected; automatic reset.
12. Internal fin cooled.
13. Totally enclosed light weight easy to access top junction box.
14. Class F rated insulation.
15. Minimal AMP draw: full load current at rated voltage, 2.3 AMPS.
16. Weight: 43.2 lbs (19.6Kg).
17. Oil capacity: 0.21 gal (0.8 L)

SYF-2M Series

Center-drive Worm Gear Motor

Installation and contour dimension (dimensions are in inch):

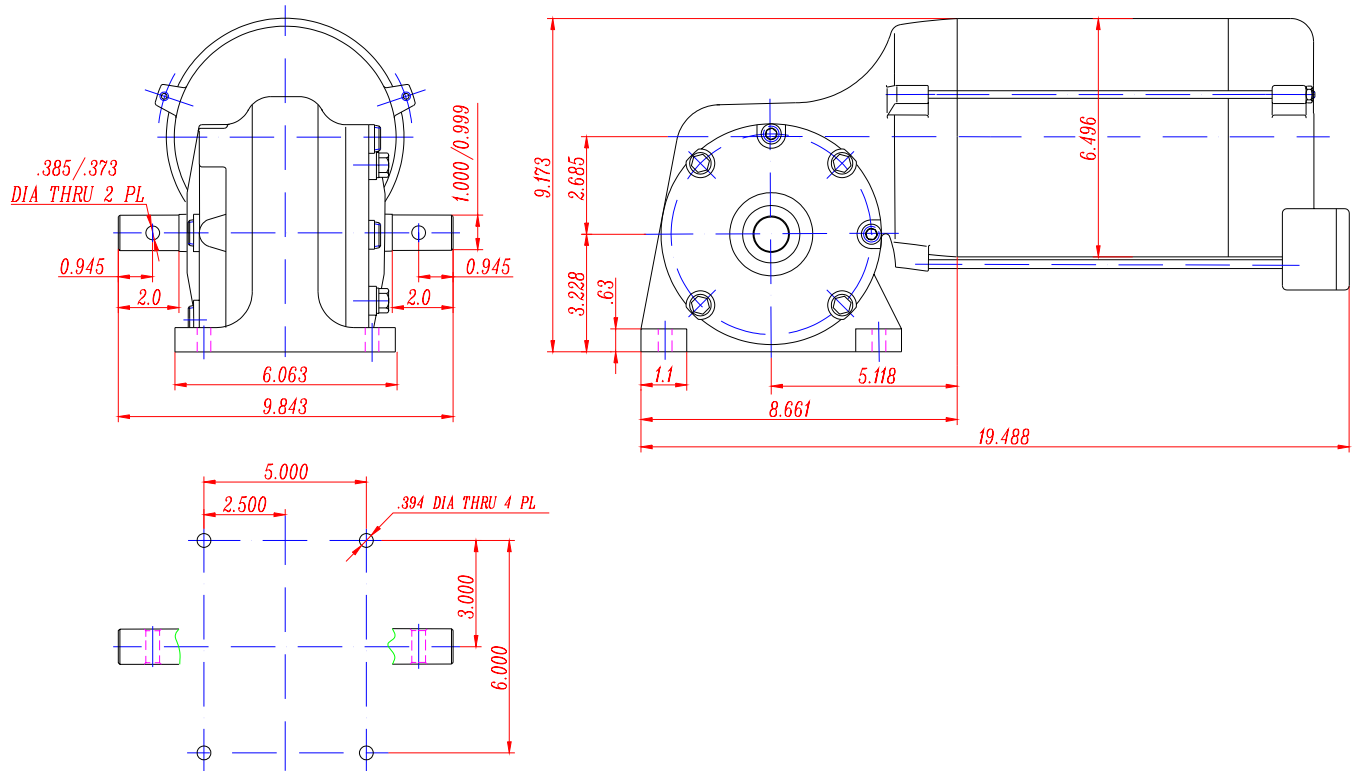

EVER-POWER TRANSMISSION CO., LTD.

<http://www.china-reducers.com>

E-Mail: shen@china-reducers.com

Phone: 0086-571-88220971

Fax: 0086-571-88220972

SYF-3 Series

Center-drive Gearbox

Model Numbers:

SYF-3M-20=87rpm(20:1 ratio, 1-1/2 HP motor)

SYF-3M-30=58rpm(30:1 ratio, 1HP motor)

SYF-3M-40-4P=43rpm(40:1 ratio, 3/4 HP and 4 poles motor)

SYF-3M-40-6P=28rpm(40:1 ratio, 1/2 HP and 6 poles motor)

SYF-3-20=87rpm(20:1 ratio, without motor)

SYF-3-30=58rpm(30:1 ratio, without motor)

SYF-3-40=43rpm(40:1 ratio, without motor)

(When input speed is 1740 rpm)

Performance (SYF-3M type):

1. Ratio: 20:1, 30:1, 40:1 (others available).
2. Mount bolt patterns 5" × 6".
3. High strength alloy steel gear, all gear are heat treated.
4. Shipped with oil.
5. Includes special external crop guard seals.
6. Precision die cast tempered aluminum housing.
7. All critical electrical connections are encapsulated to resist penetration of moisture.
8. Specially designed for rugged irrigation duty.
9. 460/380 volt, 3 phase, 60/50 HZ dual voltage.
10. Thermally protected; automatic reset.
11. Internal fin cooled.
12. Totally enclosed light weight easy to access top junction box.
13. Class F rated insulation.
14. Minimal AMP draw: full load current at rated voltage, 2.3 AMPS.
15. Weight: 60 lbs (27 Kg).
16. Oil capacity: 0.53 gal (2.0 L)
17. Efficiency 90%



SYF-3M Series

Center-drive Gear Motor

SYF-3 Series

Center-drive Gearbox

Performance (SYF-3 type):

1. Torque capacity: 10,000 lb.in (1130 N.m).
2. Ratio: 20:1, 30:1, 40:1 (others available).
3. Mount bolt patterns 5" × 6".
4. High strength alloy steel gear, all gear are heat treated.
5. Shipped with oil.
6. Includes easy installing shock absorbing motor to gearbox coupler.
7. Includes special external crop guard seals.
8. Precision die cast tempered aluminum housing.
7. Accepts NEMA 56-C face motors with 0.625" shafts, 2" long with 0.19" key slot.
9. Weight: 35 lbs (16 Kg).
10. Oil capacity: 0.53 gal (2.0 L)
11. Efficiency 90%.

Gear motor installation and contour dimension (SYF-3M type):

(dimensions are in inch)

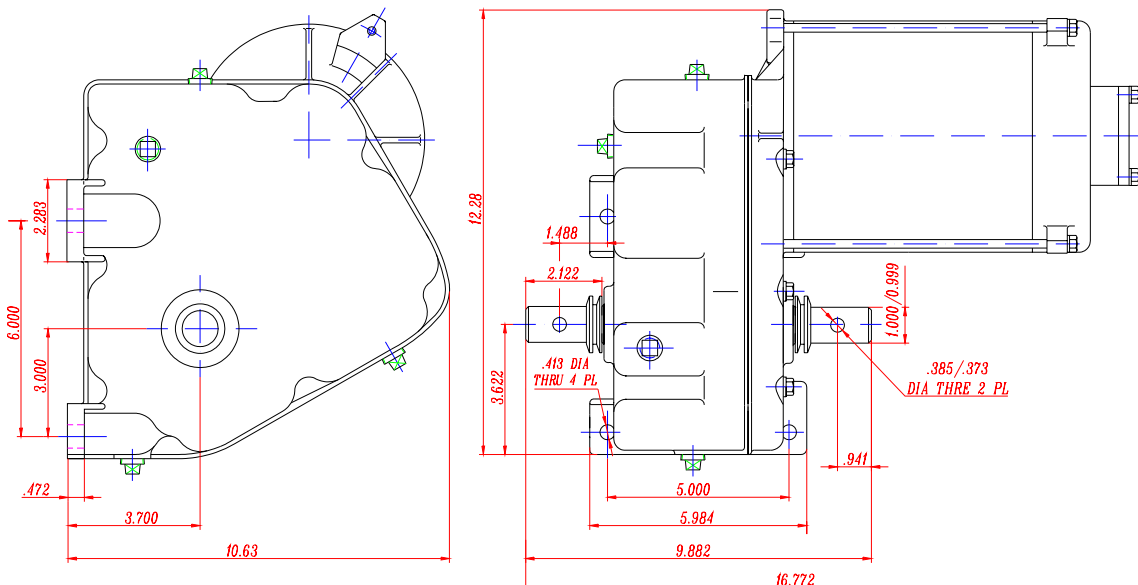

SYF-3M Series

Center-drive Gear Motor

SYF-3 Series

Center-drive Gearbox

Gearbox installation and contour dimension (SYF-3 type, without motor):
(Dimensions are in inch)

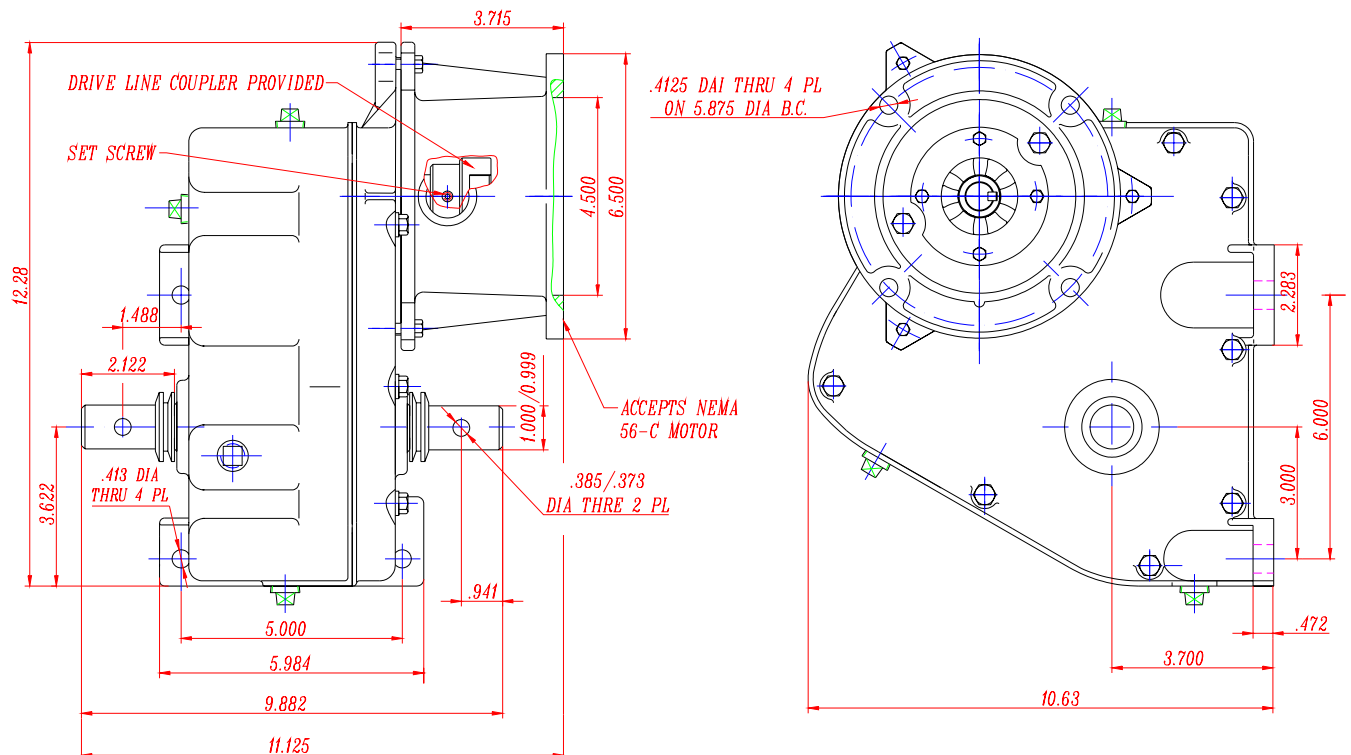

EVER-POWER TRANSMISSION CO., LTD.

<http://www.china-reducers.com>

E-Mail: shen@china-reducers.com

Phone: 0086-571-88220971

Fax: 0086-571-88220972

SYF-4 M Series

SYF-4 Series

Micro pivot Center-drive gear motor and gearbox



Model Numbers:

SYF-4M=4.75rpm

(254:1 ratio, 1/8 HP 48V DC motor)

(When input speed is 1200 rpm)

SYF-4=6.8rpm (254:1 ratio, without motors)

(Accepts NEMA 48-C face motors with 1/2" shafts
1-9/16" long)

(When input speed is 1740 rpm)

Performance (SYF-4M type):

1. Ratio: 254:1 (others available).
2. Mount bolt patterns 3.375" × 4.5".
3. High strength alloy steel gear, all gear are heat treated.
4. Shipped with oil.
5. Includes special external crop guard seals.
6. Precision die cast tempered aluminum housing.
7. All critical electrical connections are encapsulated to resist penetration of moisture.
8. Specially designed for rugged irrigation duty.
9. Permanent magnet DC motor, 1/8 HP, 48Volt.
10. Class F rated insulation.
11. Minimal AMP draw: full load current at rated voltage, 2.45 AMPS.
12. Weight: 21.5 lbs (9.8 Kg).
13. Oil capacity: 0.13 gal (0.5 L)
14. Efficiency 90%

SYF-4 M Series

SYF-4 Series

Micro pivot Center-drive gear motor and gearbox

Performance (SYF-4 type):

1. Ratio: 254:1 (others available).
2. Torque capacity: 3,500 lb.in (395 N.m).
3. Mount bolt patterns 3.375" × 4.5".
4. High strength alloy steel gear, all gear are heat treated.
5. Shipped with oil.
6. Includes special external crop guard seals.
7. Precision die cast tempered aluminum housing.
8. Includes easy installing shock absorbing motor to gearbox coupler.
9. Accepts NEMA 48-C face motors with 0.5" shafts, 1-9/16" long.
10. Weight: 15.5 lbs (7.1 Kg).
11. Oil capacity: 0.13 gal (0.5 L)
12. Efficiency 90%

Gear motor installation and contour dimension (SYF-4M type): (dimensions are in inch)

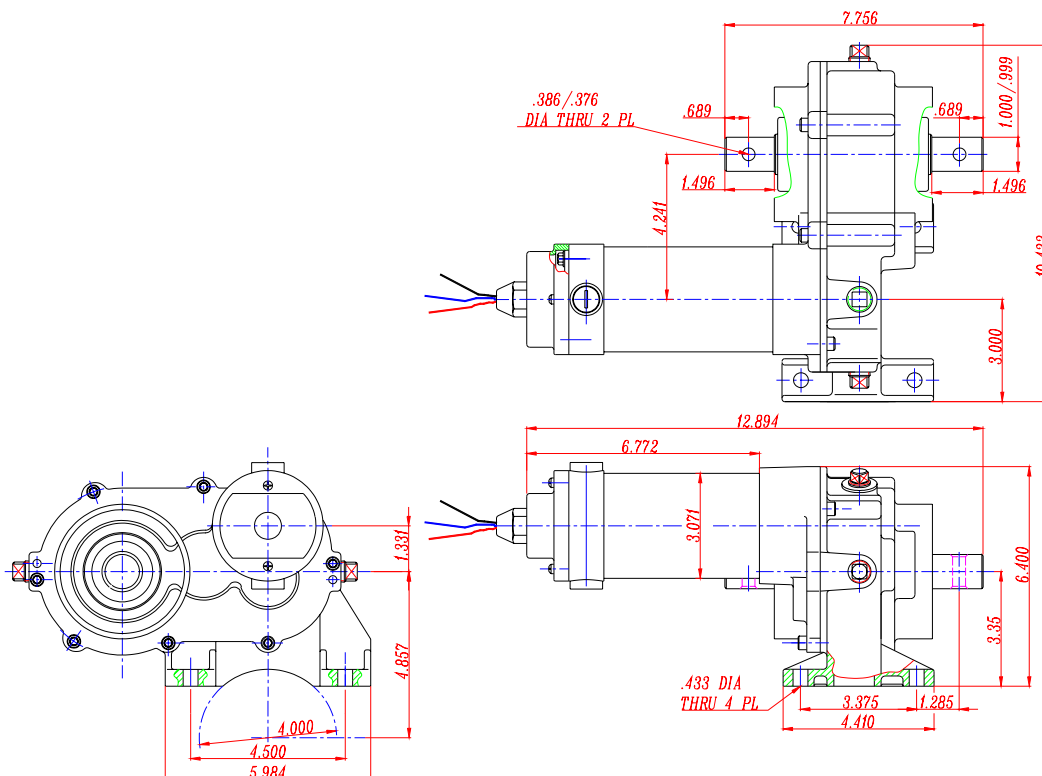

SYF-4 M Series

SYF-4 Series

Micro pivot Center-drive gear motor and gearbox

Gearbox installation and contour dimension (SYF-4 type, without motor):

(dimensions are in inch)

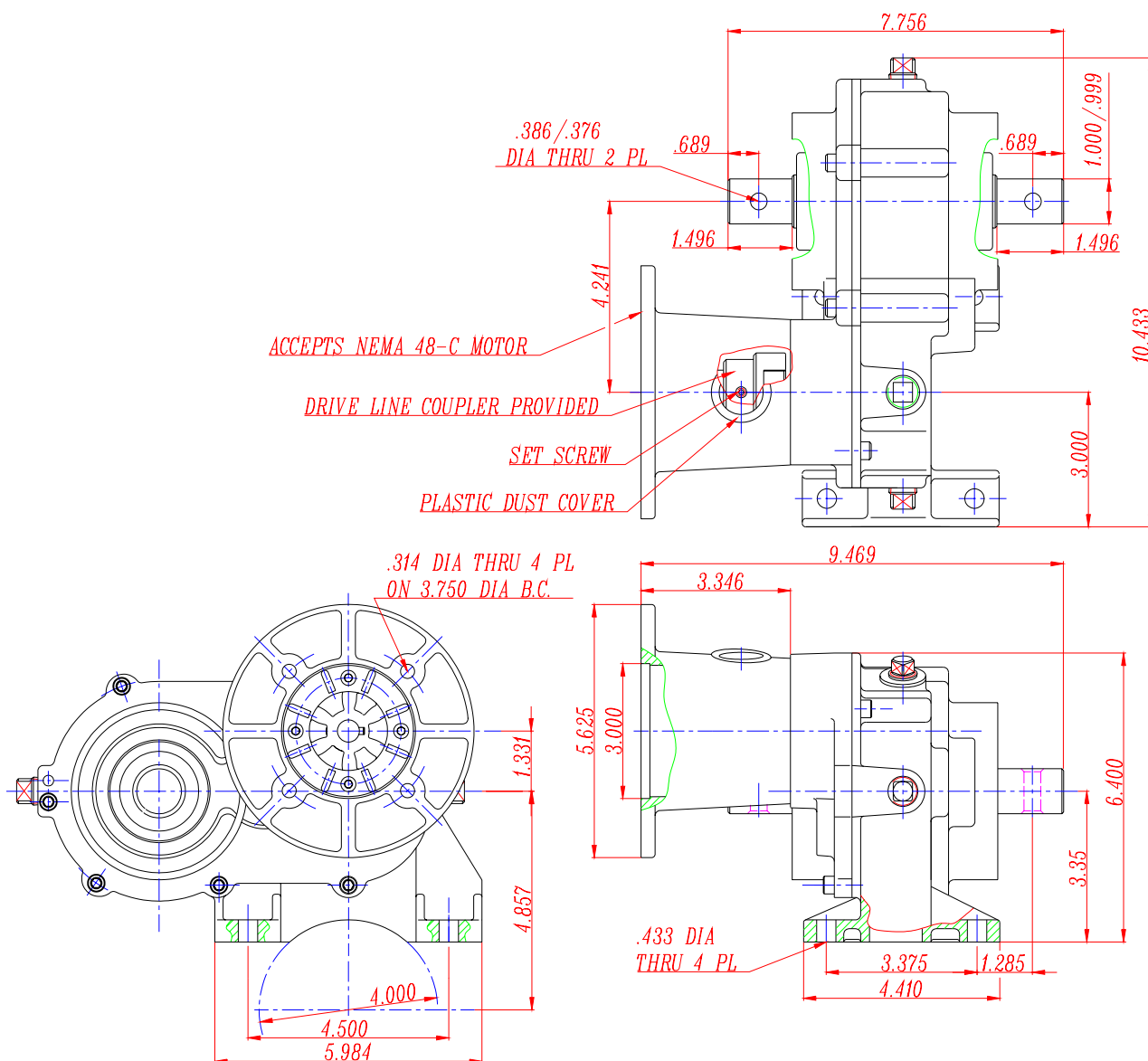

EVER-POWER TRANSMISSION CO., LTD.

<http://www.china-reducers.com>

E-mail: hzpt@hzpt.com

Phone: 0086-571-88220971 Fax: 0086-571-88220972

AEP-1 Series

Final-drive Worm Gear Box (Wheel-drive Worm Gear Box)



Model Numbers:

AEP-1-50

=(50:1 ratio, standard)

AEP-1V-52

=(52:1 ratio, replaces Valley drives)

Performance:

1. Torque capacity: 69,000 lb.in (7800 N.m)
2. Ratio: 50:1, 52:1 (others available).
3. Universal mount bolt pattern, allows usage on virtually all pivots.
4. High strength steel worm, gear, and output shaft.
5. Shipped with oil.
6. Includes special external crop guard seals.
7. High strength cast iron box and end caps.
8. Includes serrated shank carriage bolts with wheel nuts.
9. Full cycle expansion chamber; bellows-type expansion diaphragm.
10. Tapered roller bearings.
11. Input shaft seals fitted with triple lip for maximum protection.
12. Worm and gear are either precision finished for higher efficiency rating.
13. Totally enclosed light weight easy to access top junction box.
14. Weight: 104 lbs (47.5 Kg).
15. Oil capacity: 1.0 gal (3.9L).

AEP-1 Series

Final-dive Worm Gear Box (Wheel-drive Worm Gear Box)

Gear motor installation and contour dimension (dimensions are in inch):

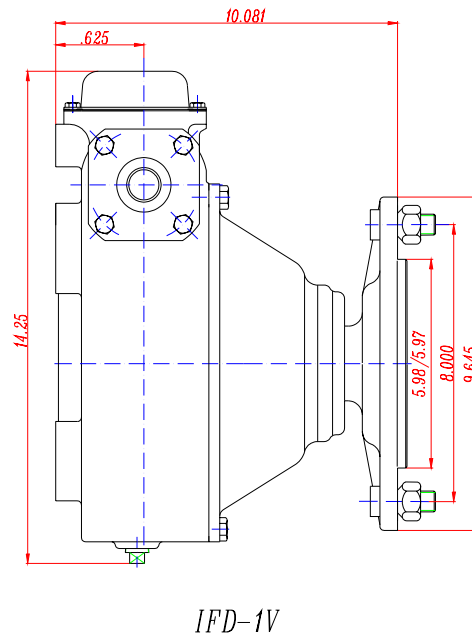
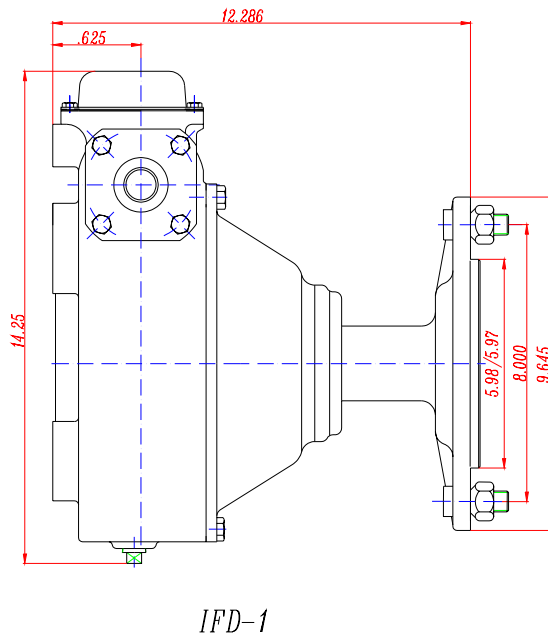
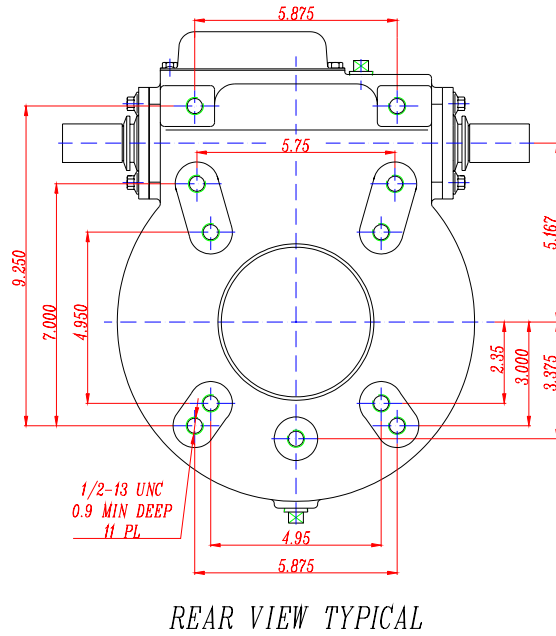
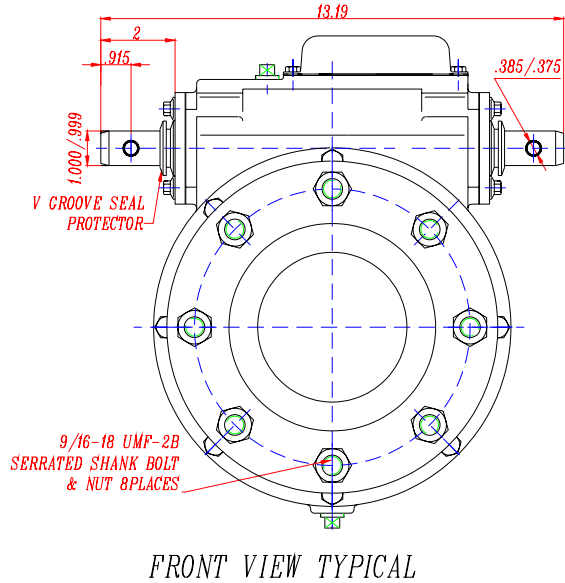

EVER-POWER TRANSMISSION CO., LTD.

<http://www.china-reducers.com> E-Mail: shen@china-reducers.com

Phone: 0086-571-88220971

Fax: 0086-571-88220972