

JDLB 系列精密蜗轮蜗杆减速器

JDLB Series high precision worm gear units

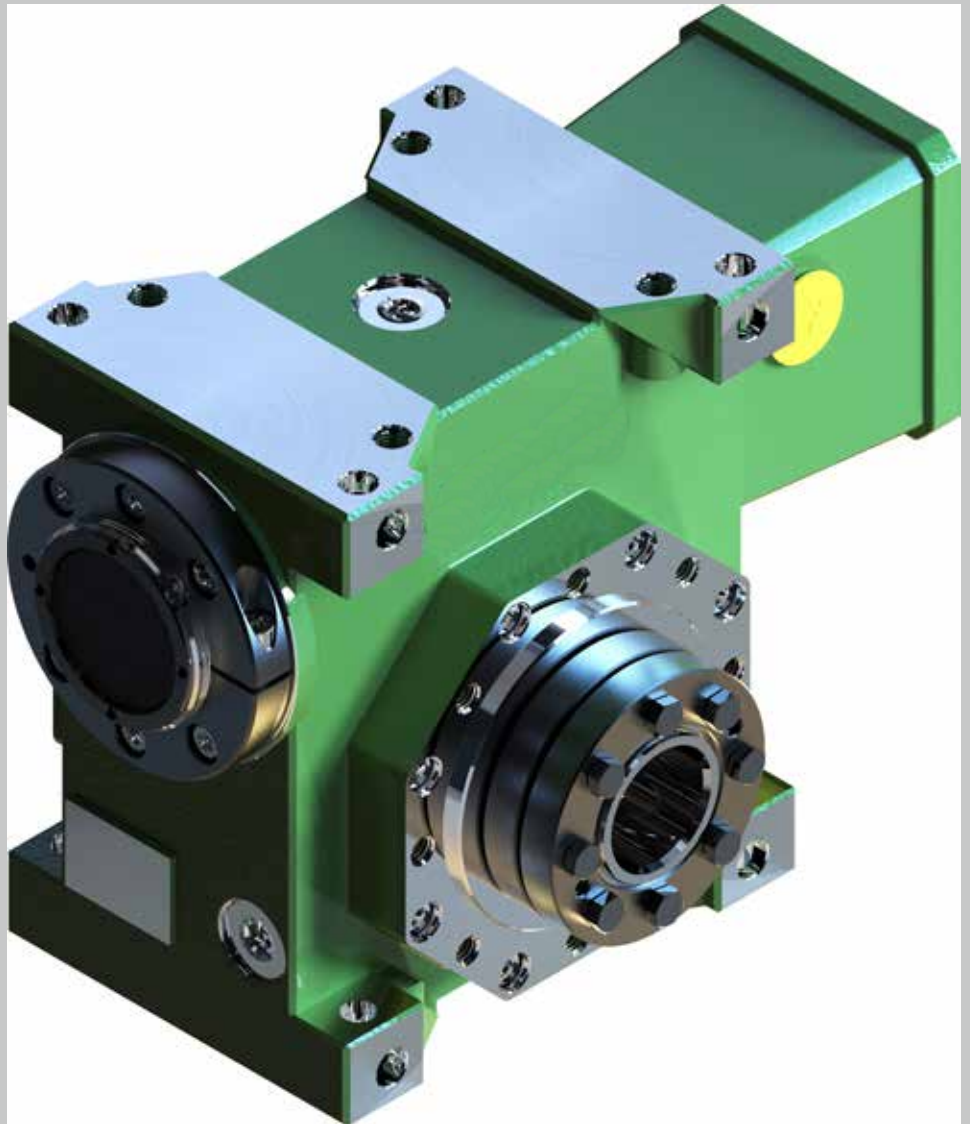

回转间隙可达 **1** 弧分
Backlash down to **1** arc minute

杭州恒力传动件有限公司
Hangzhou Ever-Power Transmission Co., Ltd

JDLB 减速器是精密行星减速器的理想替代产品，设备厂商可以大幅减少使用精密行星齿轮减速器的应用成本

JDLB series high precision worm gear is an ideal substitute for precision planetary gearbox, the equipment manufacturer can substantially reduce the cost of using precision planetary gearbox

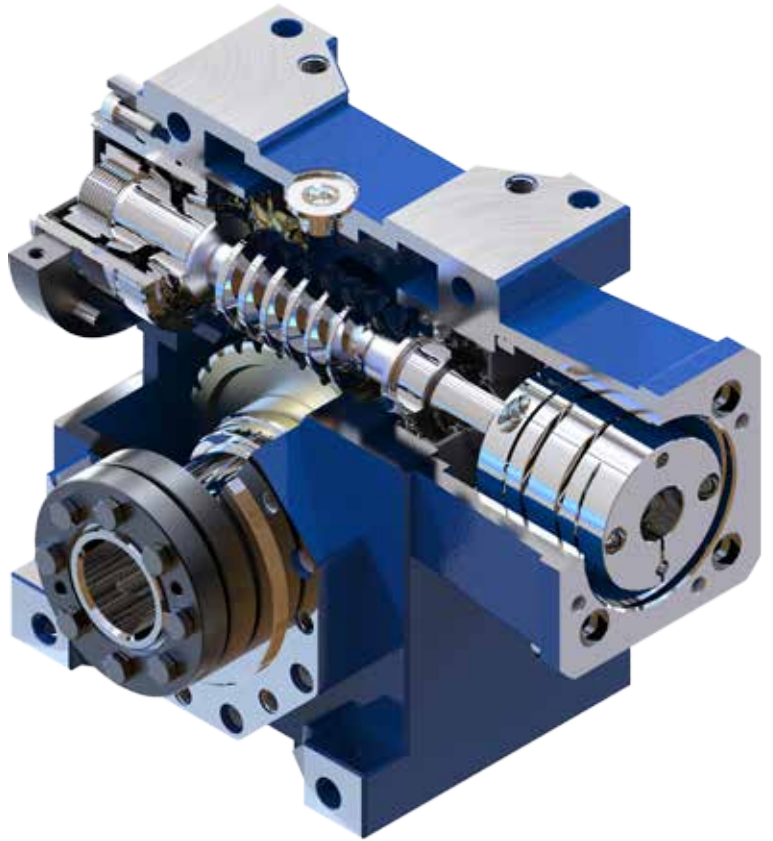

具有收缩盘的空心轴输出，精度高，容易整合
Hollow output with shrink disc, high precision, for easy integration

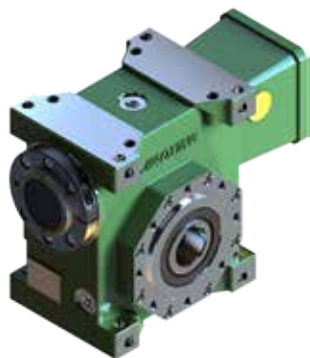

带键孔输出，安装方便，容易整合
Output with keyway, convenient installation, easy integration

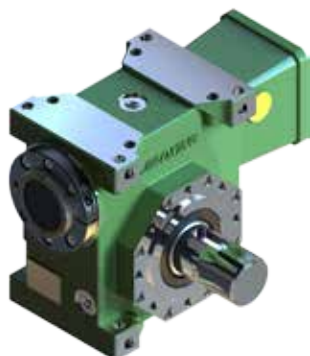

实心轴输出（单、双出轴），刚性好，传统方式
Solid shaft output (single, double), high stiffness, traditional solution

设计者的理想解决方案是旋转
90° 来安装伺服电机驱动系统
The designer's ideal solution
is to rotate 90 degrees to
install the servo motor drive
systems

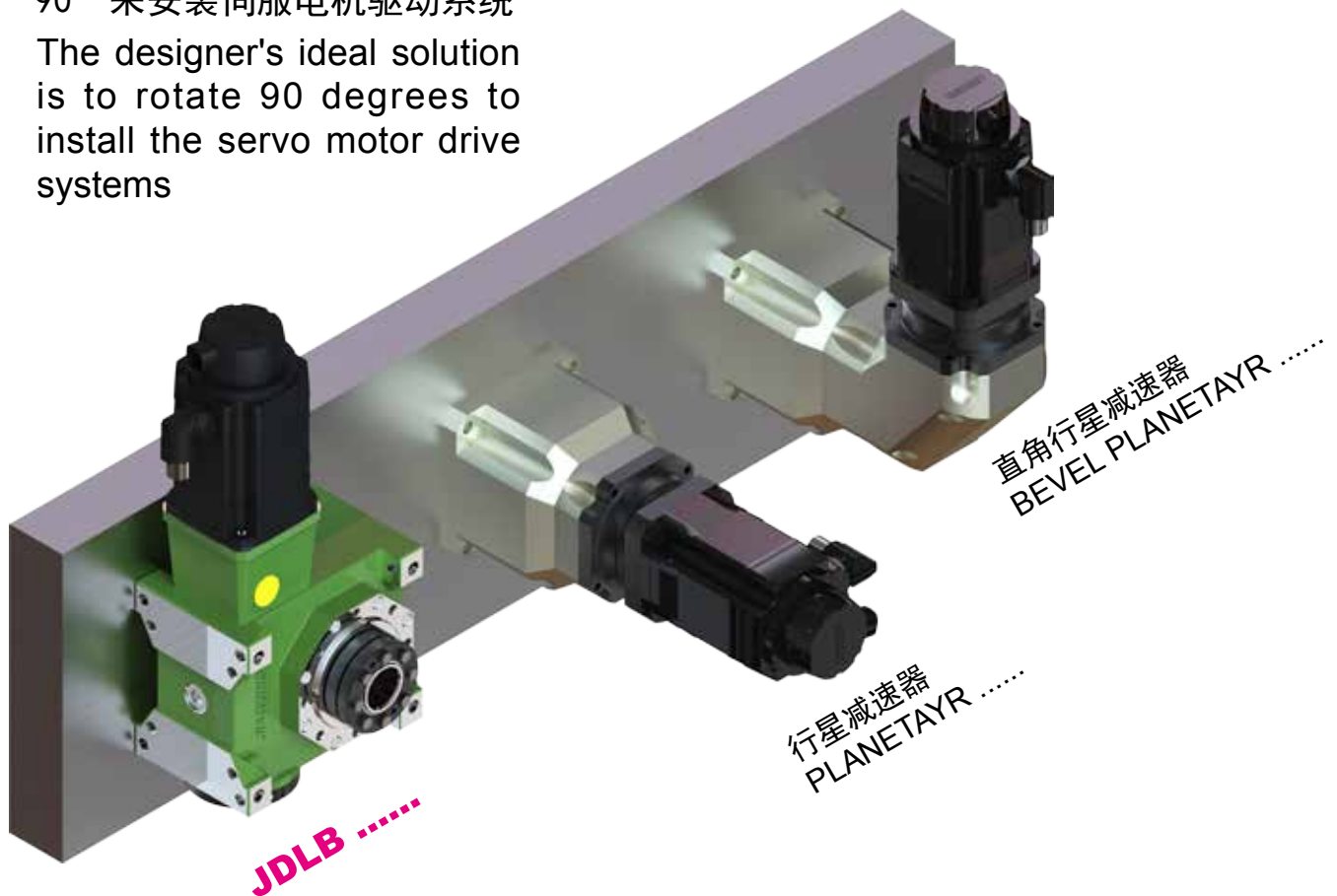

蜗杆（输入）可以串联由一个电机驱动，实现多个蜗轮同步输出。已使用于手机壳自动抛光等多种设备

Worm shaft in series can be driven by one motor to achieve synchronous output of multiple worm wheels. It has been used in automatic polishing mobile phone shell and other equipments

JDLB 系列精密蜗轮蜗杆减速器

JDLB series high precision worm gear units

优化的接触面

- * 先进的加工技术加上精密的组装，确保齿部的正确啮合，减小齿面的接触应力
- * 特殊研发的蜗轮铜合金，使齿部具有高强度及很好的耐磨性
- * 加上大比率齿面接触，蜗轮不易磨损，能长期保持锁定的侧隙

Optimized contact pattern

- * Advanced processing technology and precision assembly to ensure the correct meshing of the tooth and reduce contact stress of the tooth surface
- * Special worm wheel bronze alloy makes the teeth have high strength and good wear resistance.
- * With a large ratio of tooth surface contact, worm wheel is not easy to wear, it can maintain the locked backlash.

优化的调整结构

- * 能快速设定侧隙
- * 刚性好，精度高
- * 专利结构

Optimized adjustment structure

- * Quickly setting backlash
- * Higher stiffness and precision
- * Patent structure

免维护

- * 加装高性能全合成润滑油
- * 全封闭结构，无需更换润滑油

Maintenance free

- * High performance synthetic lubricant
- * Closed structure, no need to replace lubricant oil.

能快速安装伺服电机

- * 伺服电机专用高刚性、低惯量联轴器
- * 可提供各种和伺服电机相配的法兰

Quickly install servo motor

- * High stiffness and low inertia coupling for servo motor
- * A variety of flanges can be matched with the servo motor

蜗轮使用加大圆锥滚子轴承

- * 能承受很大的轴向负荷
- * 轴承预紧安装，具有更高的支承刚性

Installed two taper roller bearings with which have longer service lives.

- * Eliminates worm shaft alignment problems
- * Bearing pre-tight installation, with higher support stiffness

提供两种输出背隙

- * 超精密级：1 弧分，适用于要求比较高的场合
- * 精密级：2~4 弧分，品质和价格的折衷方案

Output torsional backlash available in 2 ranges:

- * Ultra precision: 1 arc minute for the most demanding applications
- * Precision: 2 to 4 arc minutes a good compromise price and quality

蜗杆使用圆锥滚子轴承

- * 一端安装两个圆锥滚子轴承，具有更长的使用寿命
- * 消除蜗杆热伸长引起的误差
- * 轴承预紧安装，具有更高的支承刚性

Worm shaft using Taper roller bearings

- * Installed two taper roller bearings with which have longer service lives.
- * Eliminates worm shaft alignment problems
- * Bearing pre-tight installation, with higher support stiffness

外壳重力浇铸成形

- * 高强度铝合金浇铸并经过热处理
- * 刚性好，重量轻
- * 外形美观耐候性好

Housing with gravity casting

- * High strength Aluminum Alloy casting and heat treatment
- * Superior rigidity and low weight
- * Beautiful shape and Good weather resisting property

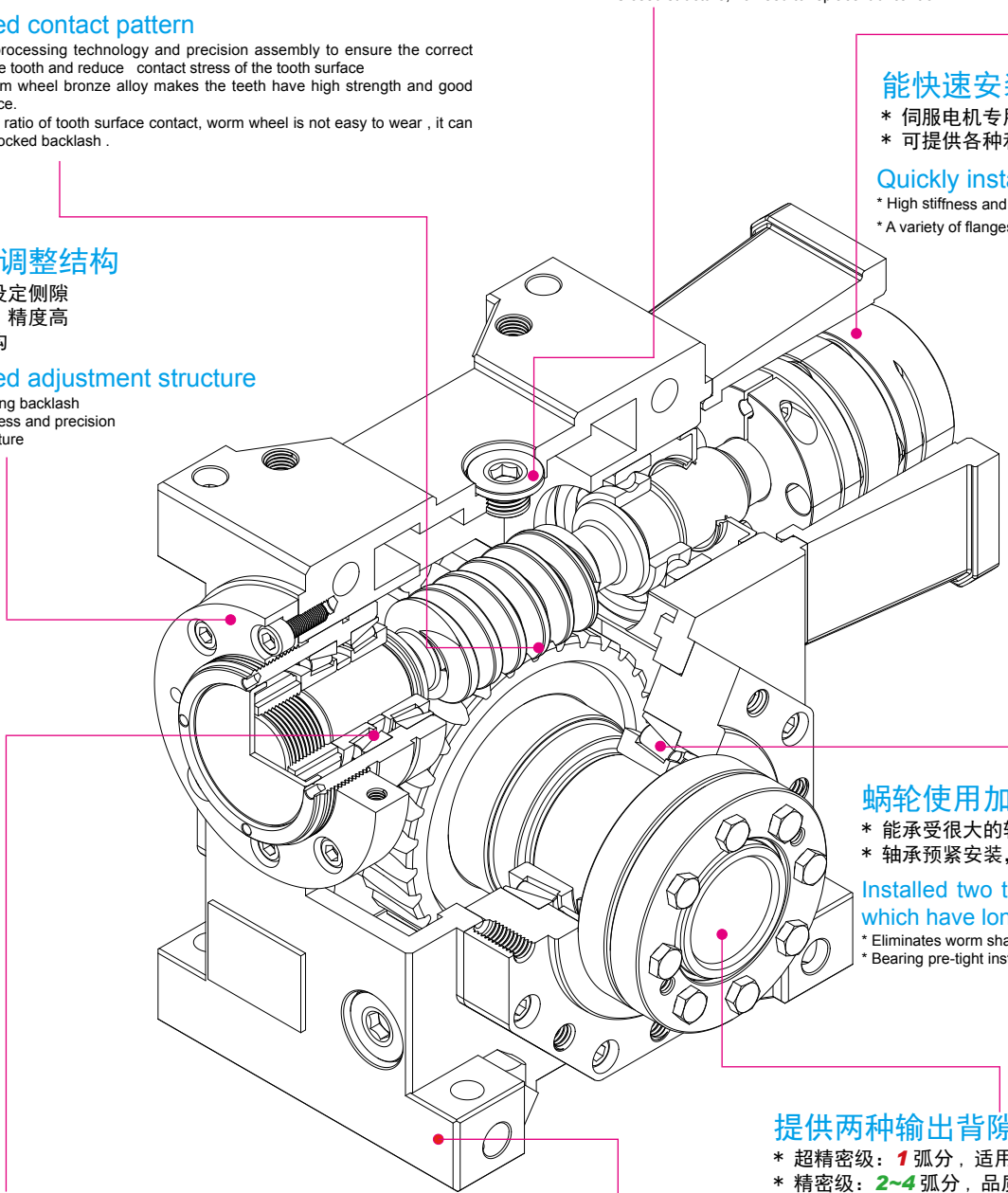

JDLB特点

蜗轮蜗杆伺服减速器有45-50-55-63-75-90六种规格，采用双导程蜗杆传动。蜗杆的左右齿面使用不同的导程角，引起齿厚的渐变，这样就可以移动蜗杆调整啮合间隙。

特点

- 蜗轮回转背隙可以调整到小于1弧分。
- 减速器使用后可以重新调整间隙。
- 输入用联轴器联结：可靠无背隙。
- 输出用锥形夹紧环联轴器：可靠无背隙。

JDLB使用场合

高精度回转运动

- 减少由负载变动及切削力变化等引起的震动及噪音。
- 减少由正反转引起的冲击及噪音。
- 减少由以上引起的蜗轮加剧磨损。
- 增加蜗轮输出的响应速度。

精密分度装置

- 数控机床、流水线、切割机、输送线等。
- 分度装置、读数机构等要求运动准确的场合。

速度有变化的场合

- 减少由速度变化引起的冲击及噪音。
- 减少由速度变化引起的蜗轮加剧磨损。

间隙调整量

JDLB Features

Servo worm gear units have six types :45 - 50 - 55 - 63 - 75 - 90 ,with dual lead worm drive .Left and right flank of worm shaft using different lead angle ,causing tooth thickness gradual change,So that you can move worm shaft and adjust backlash.

Features

- Worm gear gyration backlash can be adjusted to less than 1 arc.
- Reducer can be re-adjusted the gap after using .
- Input with coupling : reliable without backlash .
- Output using conical clamping ring couplings : reliable without backlash.

JDLB Applications

Precision rotary motion

- Reducing the noise and vibration that is caused by the load change and the change of cutting force.
- reducing the noise and impact that is caused by the corotation and reverse.
- By reducing worm abrasion.
- Increasing worm output response speed .

Precision Indexing device

- CNC machine, assembly line, cutting machine, transmission lines, etc.
- Indexing device,accurate reading mechanism require accurate movement occasions .

Speed changing situations

- Reducing the noise and the impact that is caused by speed change.
- Reducing the worm abrasion that is caused by speed changes.

Clearance Adjustment

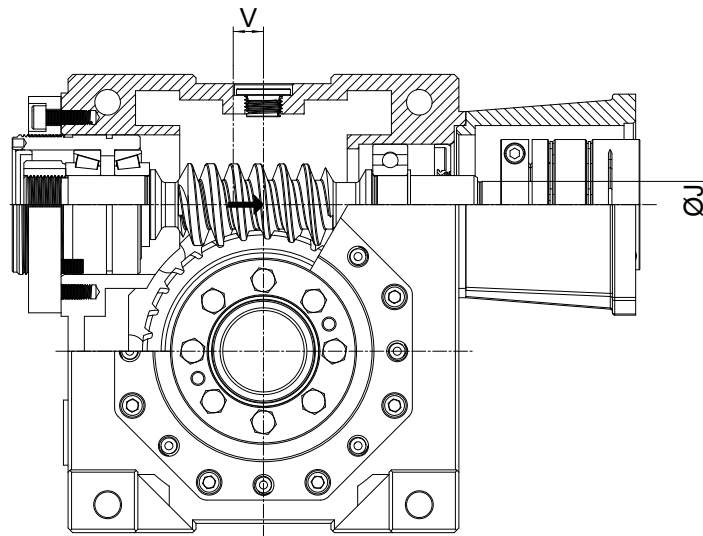

JDLB	调整距离 Adjust the distance	调整量系数 Adjustment coefficient	间隙调整量 Clearance Adjustment	输入轴直径 Input shaft diameter
	V [mm]	k [mm ⁻¹]	ΔS_d [mm]	J [mm]
045	8	0.02-0.04	0.16-0.32	15
050	8	0.015-0.03	0.12-0.24	15
055	8	0.015-0.05	0.12-0.4	18
063	10	0.03-0.05	0.3-0.5	20
075	13	0.03-0.06	0.39-0.78	24
090	13	0.03-0.06	0.39-0.78	28

JDLB 选型

下列的标题包含选择减速器的原理以及正确使用它们的方法。

具体的数值参照相应的章节

1.0 输出扭矩

1.1 额定扭矩 M_{n2} [Nm]

扭矩作用于连续平稳运转的减速器且在工作系数 $f_s = 1$ 的情况下测出的数值。

1.2 需求的扭矩 M_{r2} [Nm]

基于实际所需，数值等于或小于减速器的额定扭矩 M_{n2} 。

1.3 计算扭矩 M_{c2} [Nm]

在选择减速器时有用。它要考虑实际需求的扭矩 M_{r2} 以及工作系数 f_s ，由以下关系式计算出：

$$M_{c2} = M_{r2} \cdot f_s \leq M_{n2}$$

2.0 功率

2.1 额定输入功率 P_{n1} [kW]

减速器安全运转时的功率(kW)值，列于参数表中。它是在速度等于 n_1 且工作系数 $f_s = 1$ 的情况下得出的。

2.2 额定输出功率 P_{n2} [kW]

减速器的输出功率值，可以用下面的公式计算。

$$P_{n2} = P_{n1} \cdot \eta_d$$

$$P_{n2} = \frac{M_{n2} \cdot n_2}{9550}$$

3.0 效率

效率是影响某些应用的主要因素，它的值基本由齿轮副设计的参数决定。

在第9页上的啮合参数表上记录了动态及静态效率值 ($n_1=1400$)。

注意这些值只适用于磨合完成的在工作温度下运转的减速箱

JDLB Make choice

The following headings contain information on essential elements for selection and correct use of gearbox.

For specific data on the gearbox range, see the relevant chapters.

1.0 OUTPUT TORQUE

1.1 Rated output torque M_{n2} [Nm]

The torque that can be transmitted continuously through the output shaft, with the gear unit operated under a service factor $f_s = 1$.

1.2 Required torque M_{r2} [Nm]

The torque demand based on application requirement. It is recommended to be equal to or less than torque M_{n2} the gearbox under study is rated for.

1.3 Calculated torque M_{c2} [Nm]

Computational torque value to be used when selecting the gearbox. It is calculated considering the required torque M_{r2} and service factor f_s , as per the relationship here after:

2.0 POWER

2.1 Rated input power P_{n1} [kW]

The parameter can be found in the gearbox rating charts and represents the KW that can be safely transmitted to the gearbox, based on input speed n_1 and service factor $f_s = 1$.

2.2 Rated output power P_{n2} [kW]

This value is the power transmitted at gearbox output. it can be calculated with the following formulas:

3.0 EFFICIENCY

Efficiency is a parameter which has a major influence on the sizing of certain applications, and basically depends on gear pair design elements. The mesh data table on page 9 shows dynamic efficiency ($n_1=1400$) and static efficiency values.

Remember that these values are only achieved after the unit has been run in and is at the working temperature.

产品名称

DESIGNATION

类型 Type 减速比 Ratio 输出 Output 背隙 Backlash 安装方位 Mounting position 颜色 Color 电机 Electric motor
JDLB075 - 30 - C1 - P0 - B3 - B - 1FK7042...

电机型号
Motor type

颜色/Color

B = 银灰色/Silver gray L = 蓝色/Blue O=橄榄绿/Olive

安装方位/Mounting position (P9)

B3, B6, B7, B8, V5, V6

背隙/Backlash

P0 1弧分 (超精密级/Ultra precision)

P1 2~4弧分 (精密级/Precision)

输出轴/Output shaft

C (锁紧盘孔输出/Hollow shaft for shrink disc)

CR (键槽孔输出/Hollow shaft with keyway)

P (单出轴/Single output shaft)

2P (双出轴/Dual output shaft)

1, 2 (安装位置/Mounting side)

减速比/Reduction ratio

15,20,25,30,40,50,60,80,100

减速器尺寸/Gearbox size

45,50,55,63,75,90

减速器类型
Reducer type

JDLB 输出方位

JDLB output Position

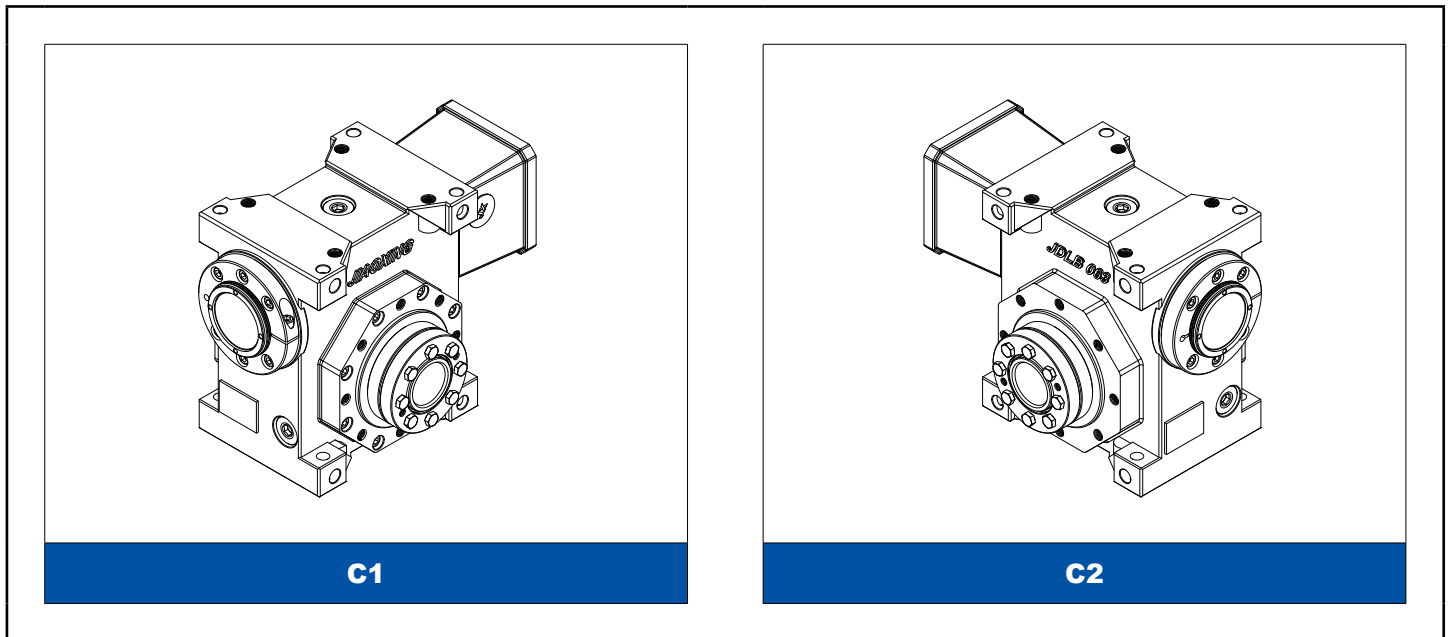

如无特殊说明，锁紧环联轴器安装在C1的位置

The shrink disc is supplied in C1 position, if no special instructions

JDLB 版本

JDLB Versions

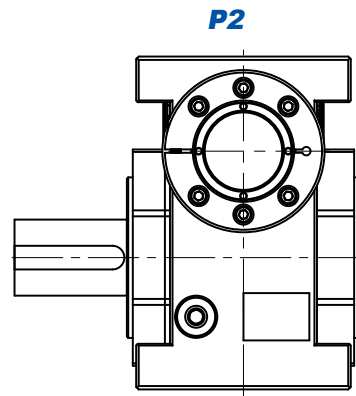
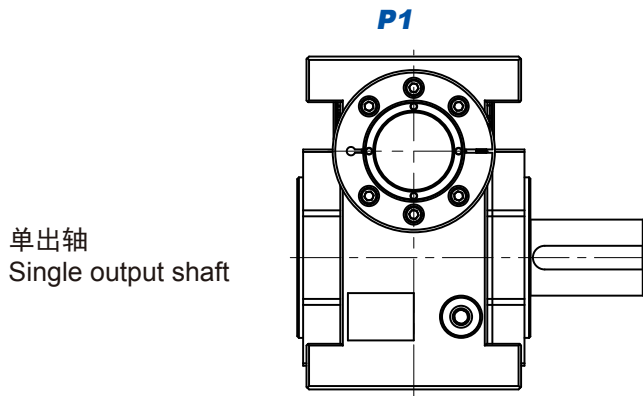
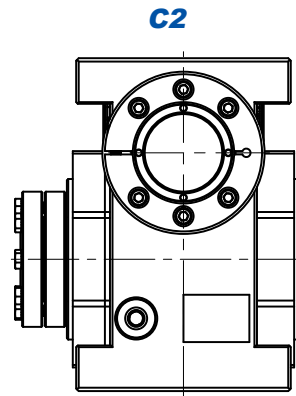
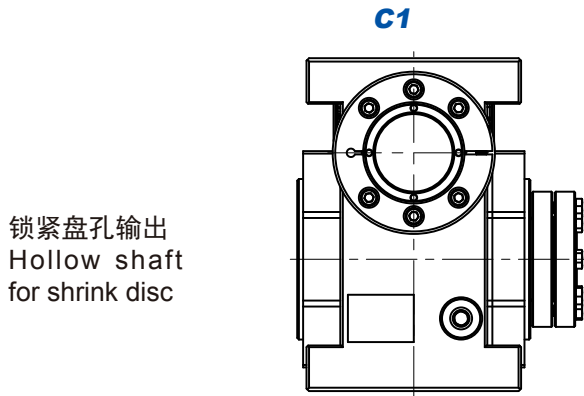

JDLB 啮合参数

JDLB MESH DATA

蜗杆螺旋线、蜗轮齿牙和效率 (n1=1400)

Worm thread, worm wheel tooth and efficiency data (n1=1400)

JDLB	i	15	20	25	30	40	50	60	80	100
045	Z ₁	2	2	2	1	1	1	1		
	γ	14°06'	11°33'	9°44'	7°10'	5°50'	4°54'	4°14'		
	M _x	2.35	1.8	1.45	2.35	1.8	1.45	1.22		
	η _d	0.80	0.77	0.74	0.69	0.64	0.61	0.57		
	η _s	0.58	0.53	0.5	0.44	0.4	0.36	0.32		
050	Z ₁	2	2	2	1	1	1	1		
	γ	11°18'	9°04'	7°36'	5°42'	4°33'	3°49'	3°17'		
	M _x	2.5	1.9	1.54	2.5	1.9	1.54	1.3		
	η _d	0.8	0.77	0.74	0.7	0.65	0.61	0.57		
	η _s	0.58	0.54	0.5	0.44	0.39	0.35	0.32		
055	Z ₁	2	2	2	1	1	1	1	1	
	γ	12°20'	10°02'	8°23'	6°14'	5°03'	4°13'	3°37'	2°48'	
	M _x	2.8	2.15	1.73	2.8	2.15	1.73	1.45	1.09	
	η _d	0.81	0.78	0.75	0.71	0.66	0.62	0.58	0.53	
	η _s	0.58	0.54	0.5	0.44	0.39	0.35	0.32	0.27	
063	Z ₁	2	2	2	1	1	1	1		
	γ	12°50'	10°29'	8°44'	6°30'	5°17'	4°23'	3°47'		
	M _x	3.25	2.5	2	3.25	2.5	2	1.68		
	η _d	0.82	0.8	0.77	0.73	0.69	0.65	0.61		
	η _s	0.59	0.54	0.5	0.45	0.4	0.36	0.33		
075	Z ₁	2	2	2	1	1	1	1	1	
	γ	14°02'	11°18'	9°37'	7°07'	5°42'	4°50'	4°05'	3°15'	
	M _x	4	3	2.45	4	3	2.45	2	1.54	
	η _d	0.84	0.81	0.79	0.75	0.71	0.68	0.64	0.59	
	η _s	0.6	0.57	0.52	0.46	0.42	0.38	0.35	0.29	
090	Z ₁	2	2	2	1	1	1	1	1	1
	γ	15°05'	12°14'	10°37'	7°40'	6°11'	5°21'	4°36'	3°36'	2°57'
	M _x	4.8	3.6	3	4.8	3.6	3	2.5	1.88	1.5
	η _d	0.85	0.83	0.81	0.77	0.74	0.71	0.68	0.62	0.58
	η _s	0.63	0.59	0.55	0.49	0.45	0.41	0.38	0.32	0.28

JDLB 安装方位

JDLB Mounting positions

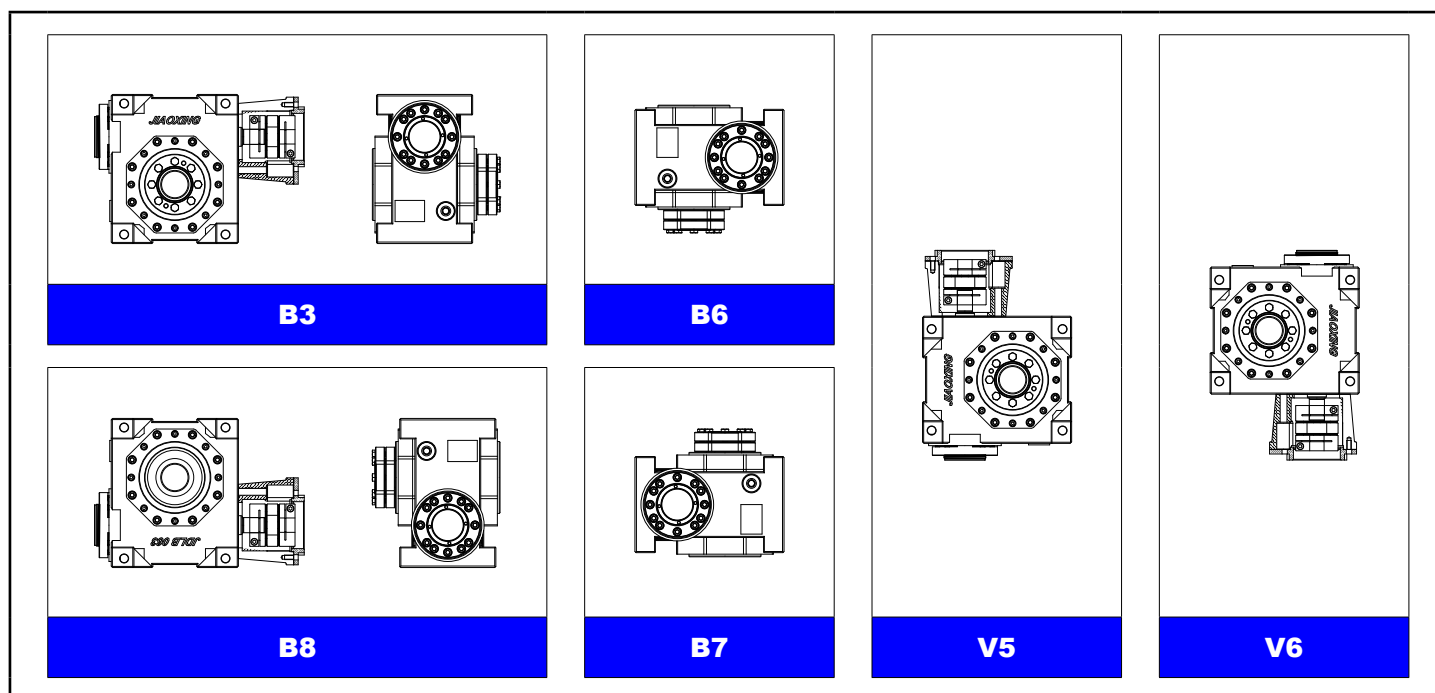

JDLB 性能参数

JDLB Performance

n1		3000				1400				900					
JDLB	i	η_d Effi.	P ₁ [kW]	M ₂ [Nm]	n ₂ [min ⁻¹]	η_d Effi.	P ₁ [kW]	M ₂ [Nm]	n ₂ [min ⁻¹]	η_d Effi.	P ₁ [kW]	M ₂ [Nm]	n ₂ [min ⁻¹]	Fr ₂ [N]	Fa ₂ [N]
045	15	0.85	1.1	44	200	0.80	0.6	52	93.3	0.74	0.5	58	60	5500	3800
	20	0.82	0.9	46	150	0.77	0.5	54	70.0	0.71	0.4	60	45	5500	3800
	25	0.79	0.7	47	120	0.74	0.4	55	56.0	0.68	0.3	61	36	5500	3800
	30	0.74	0.7	52	100	0.69	0.4	61	46.7	0.63	0.3	67	30	5500	3800
	40	0.69	0.6	49	75	0.64	0.3	57	35.0	0.58	0.3	62	22.5	5500	3800
	50	0.66	0.5	50	60	0.61	0.3	58	28.0	0.55	0.2	63	18	5500	3800
	60	0.62	0.4	49	50	0.57	0.2	57	23.3	0.51	0.2	62	15	5500	3800
050	15	0.85	1.4	57	200	0.80	0.9	74	93.3	0.74	0.7	84	60	5500	3800
	20	0.82	1.0	53	150	0.77	0.7	73	70.0	0.71	0.5	77	45	5500	3800
	25	0.79	0.8	51	120	0.74	0.6	70	56.0	0.68	0.4	75	36	5500	3800
	30	0.75	0.9	64	100	0.70	0.6	84	46.7	0.64	0.4	90	30	5500	3800
	40	0.7	0.7	59	75	0.65	0.4	76	35.0	0.59	0.3	82	22.5	5500	3800
	50	0.66	0.5	53	60	0.61	0.4	73	28.0	0.55	0.3	77	18	5500	3800
	60	0.62	0.4	50	50	0.57	0.3	68	23.3	0.51	0.2	72	15	5500	3800
055	15	0.86	2.1	85	200	0.81	1.2	101	93.3	0.75	0.9	112	60	6700	4600
	20	0.83	1.7	88	150	0.78	1.0	105	70.0	0.72	0.8	116	45	6700	4600
	25	0.8	1.4	92	120	0.75	0.8	108	56.0	0.69	0.7	120	36	6700	4600
	30	0.76	1.4	100	100	0.71	0.8	118	46.7	0.65	0.6	130	30	6700	4600
	40	0.71	1.0	94	75	0.66	0.6	111	35.0	0.6	0.5	121	22.5	6700	4600
	50	0.67	0.9	92	60	0.62	0.5	108	28.0	0.56	0.4	117	18	6700	4600
	60	0.63	0.8	94	50	0.58	0.5	110	23.3	0.52	0.4	119	15	6700	4600
063	15	0.87	2.5	103	200	0.82	1.7	140	93.3	0.76	1.3	155	60	8400	8100
	20	0.85	1.8	100	150	0.80	1.2	135	70.0	0.74	0.9	148	45	8400	8100
	25	0.82	1.4	92	120	0.77	1.0	130	56.0	0.71	0.7	137	36	8400	8100
	30	0.78	1.6	120	100	0.73	1.1	160	46.7	0.67	0.8	175	30	8400	8100
	40	0.74	1.1	108	75	0.69	0.8	145	35.0	0.63	0.6	160	22.5	8400	8100
	50	0.7	0.9	100	60	0.65	0.6	135	28.0	0.59	0.5	145	18	8400	8100
	60	0.67	0.7	95	50	0.62	0.5	130	23.3	0.56	0.4	138	15	8400	8100
075	15	0.89	3.5	150	200	0.84	2.3	200	93.3	0.78	1.9	235	60	10000	10000
	20	0.86	2.9	160	150	0.81	1.9	210	70.0	0.75	1.5	235	45	10000	10000
	25	0.84	2.2	150	120	0.79	1.5	200	56.0	0.73	1.1	215	36	10000	10000
	30	0.8	2.2	170	100	0.75	1.5	230	46.7	0.69	1.2	260	30	10000	10000
	40	0.76	1.7	165	75	0.71	1.1	220	35.0	0.65	0.9	240	22.5	10000	10000
	50	0.73	1.3	150	60	0.68	0.9	210	28.0	0.62	0.7	220	18	10000	10000
	60	0.69	1.1	145	50	0.64	0.8	200	23.3	0.58	0.6	210	15	10000	10000
090	15	0.9	6.3	270	200	0.85	4.1	360	93.3	0.79	3.3	420	60	15000	12300
	20	0.88	4.6	260	150	0.83	3.1	355	70.0	0.77	2.4	390	45	15000	12300
	25	0.86	3.7	250	120	0.81	2.5	340	56.0	0.75	1.9	370	36	15000	12300
	30	0.82	4.0	310	100	0.77	2.6	410	46.7	0.71	2.0	460	30	15000	12300
	40	0.79	2.7	275	75	0.74	1.8	360	35.0	0.68	1.4	410	22.5	15000	12300
	50	0.76	2.2	265	60	0.71	1.4	340	28.0	0.65	1.1	390	18	15000	12300
	60	0.73	1.8	245	50	0.68	1.1	320	23.3	0.62	0.9	350	15	15000	12300
090	80	0.67	1.3	225	37.5	0.62	0.8	285	17.5	0.56	0.7	315	11.3	15000	12300
	100	0.63	1.0	200	30	0.58	0.7	270	14.0	0.52	0.5	280	9	15000	12300

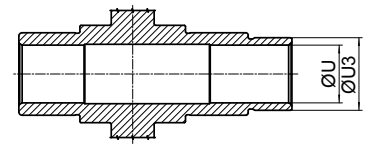
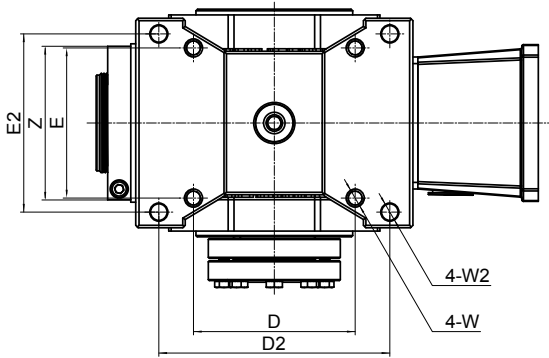
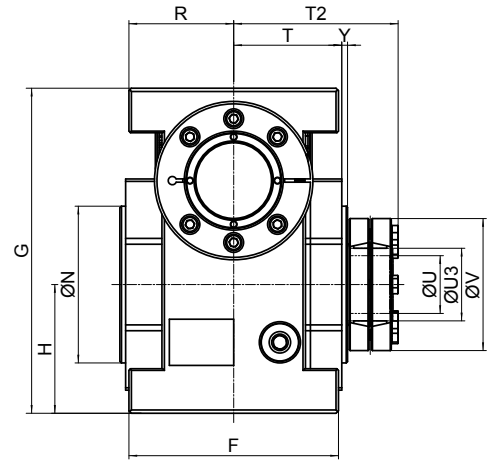
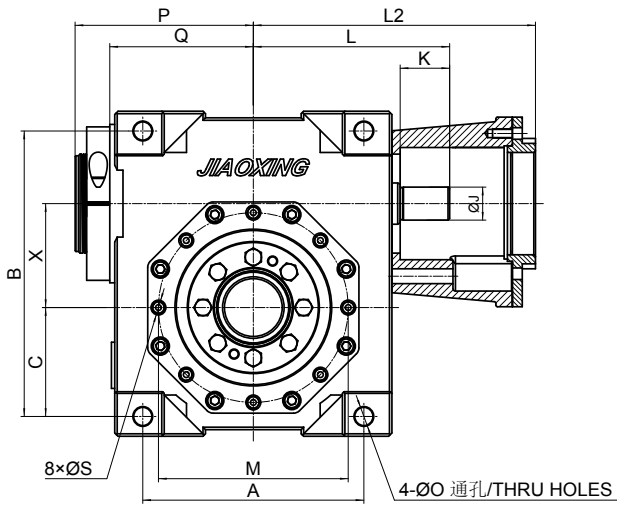

带锁紧盘孔输出/Hollow Output Bore With Shrink disc

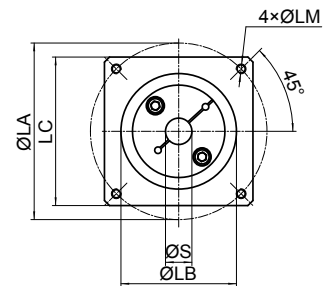
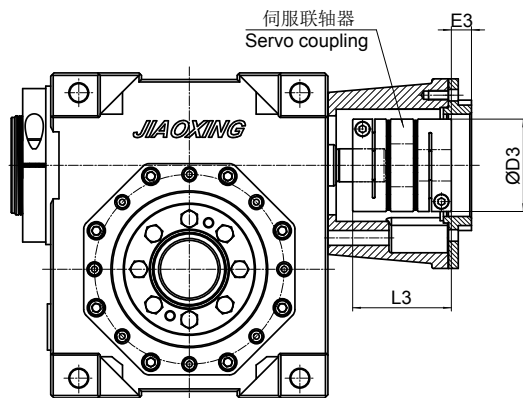

伺服电机示意图/Servo motor

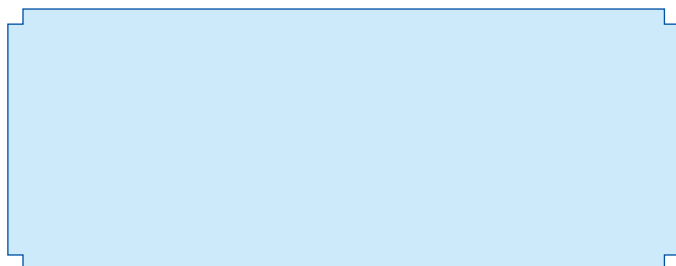

JDLB	045	050	055	063	075	090
A	108	108	120	134	172	186
B	135	138	155	173	208	234
C	53	53	61	66	82	91
D	81	81	90	98	136	141
D2	114	114	125	140	172	204
D3	44	44	56	56	68	68
E	68	68	78	91	110	130
E2	84	84	96	108	125	140
E3	5	5	6.5	6.5	6.5	6.5
F	100	100	112	127	148	170
G	153	156	175	197	232	264
H	62	62	71	78	94	106
J(h6)	15	15	18	20	24	28
K	24	24	28	30	35	35
L	98.5	98.5	111	122	147	157
L2	103+LR	103+LR	116+LR	127+LR	152+LR	162+LR
L3	48	48	59.8	59.8	73.3	73.3
M	85	85	100	115	130	165
N(h7)	70	70	80	95	110	130
O	9	9	9	11	11	13
P(max)	91	91	100	108	129	139.5
Q	70.5	70.5	78	87	107	117.5
R	50	50	56	63.5	74	85
S	M8	M8	M8	M8	M10	M12
T	52	52	58	65.5	76	87
T2	78	78	87	96.5	110	124
U(H7)	25	25	30	35	40	50
U3	30	30	36	44	50	68
V	60	60	72	80	90	115
W	M8	M8	M8	M10	M10	M12
W2	9	9	9	10	12	14
X	45	50	55	63	75	90
Y	3	3	3.5	3.5	4	4
Z	86	86	86	93	108	108
LA/LB/LC/LR/LM/S	按伺服电机 /By servo motor					

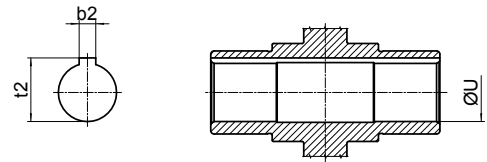
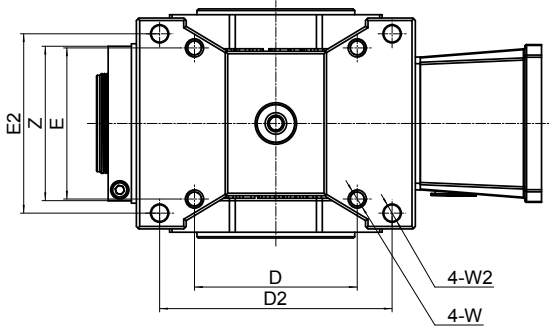
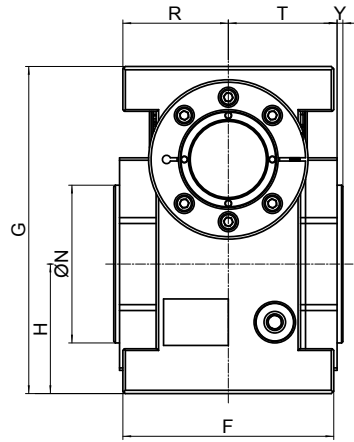
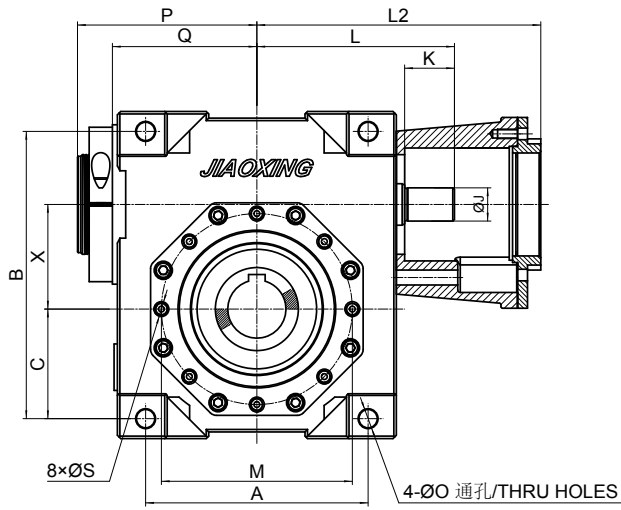

带键孔输出/Hollow Output Bore With Keyway

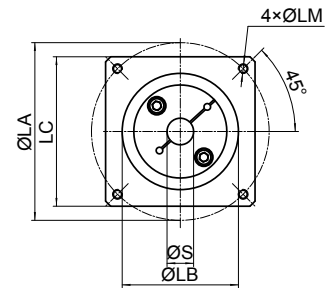
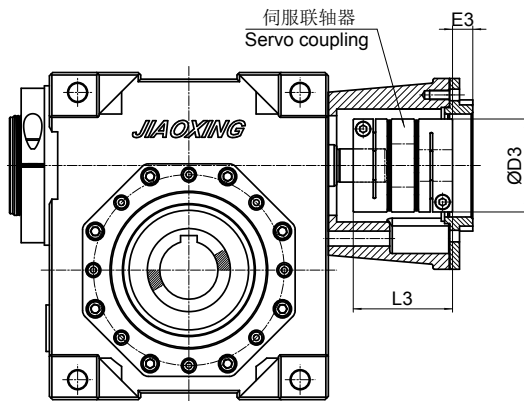

伺服电机示意图/Servo motor

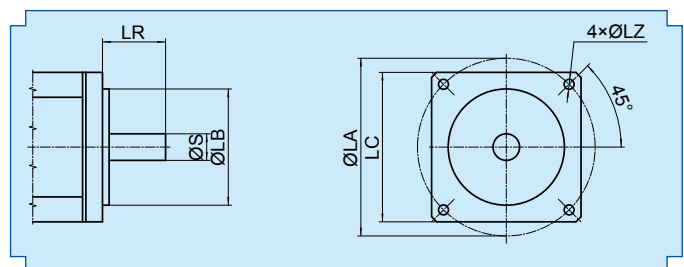

JDLB	045	050	055	063	075	090
A	108	108	120	134	172	186
B	135	138	155	173	208	234
C	53	53	61	66	82	91
D	81	81	90	98	136	141
D2	114	114	125	140	172	204
D3	44	44	56	56	68	68
E	68	68	78	91	110	130
E2	84	84	96	108	125	140
E3	5	5	6.5	6.5	6.5	6.5
F	100	100	112	127	148	170
G	153	156	175	197	232	264
H	62	62	71	78	94	106
J(h6)	15	15	18	20	24	28
K	24	24	28	30	35	35
L	98.5	98.5	111	122	147	157
L2	103+LR	103+LR	116+LR	127+LR	152+LR	162+LR
L3	48	48	59.8	59.8	73.3	73.3
M	85	85	100	115	130	165
N	70	70	80	95	110	130
O	9	9	9	11	11	13
P	91	91	100	108	129	139.5
Q	70.5	70.5	78	87	107	117.5
R	50	50	56	63.5	74	85
S	M8	M8	M8	M8	M10	M12
T	52	52	58	65.5	76	87
U(H7)	25	25	30	35	40	50
V	60	60	72	80	90	115
W	M8	M8	M8	M10	M10	M12
W2	9	9	9	10	12	14
X	45	50	55	63	75	90
Y	3	3	3.5	3.5	4	4
Z	86	86	86	93	108	108
t2	27.8	27.8	33.3	38.3	43.3	53.8
b2	6	6	8	10	12	14
LA/LB/LC/LR/LM/S	按伺服电机 /By servo motor					

JDLB 系列尺寸图

JDLB Series dimensions charts

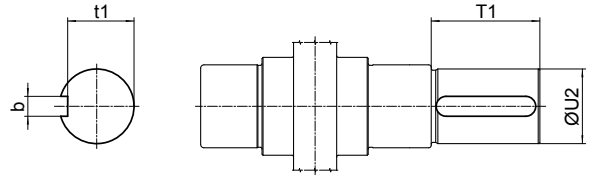
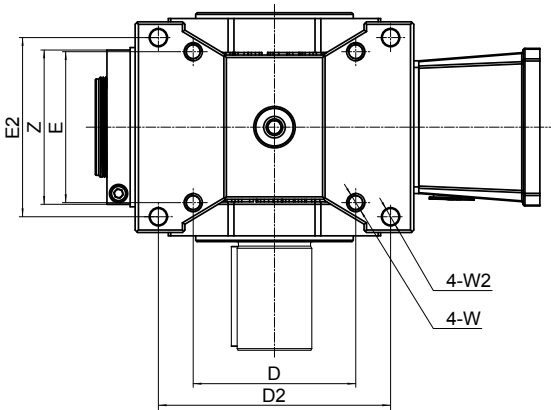
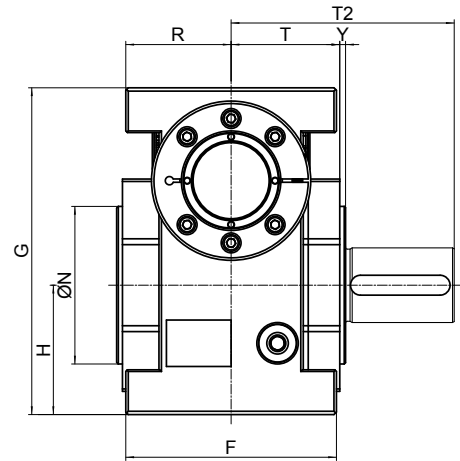
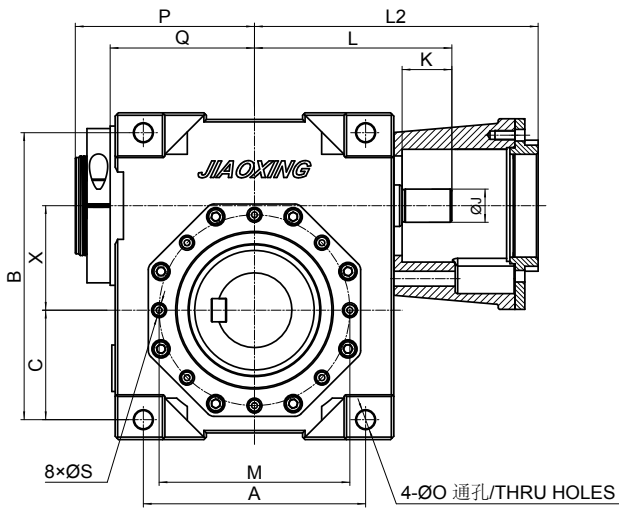

单输出轴/Single output shaft

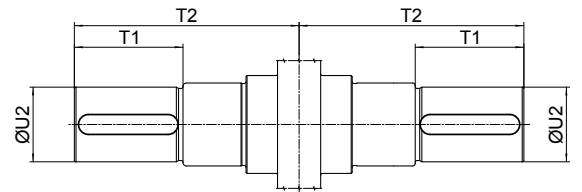

双输出轴/Double output shaft

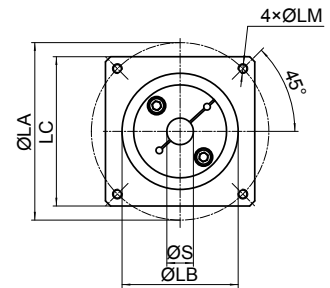
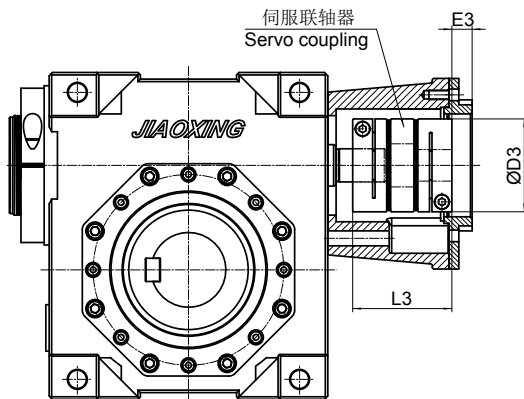

伺服电机示意图/Servo motor

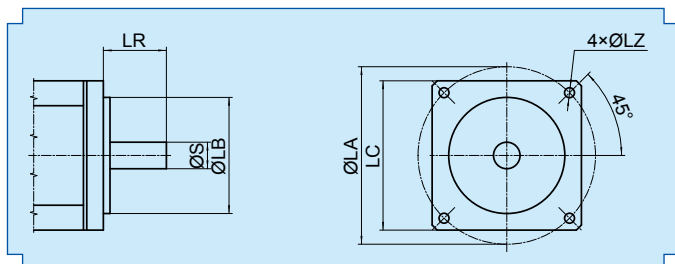

JDLB	045	050	055	063	075	090
A	108	108	120	134	172	186
B	135	138	155	173	208	234
C	53	53	61	66	82	91
D	81	81	90	98	136	141
D2	114	114	125	140	172	204
D3	44	44	56	56	68	68
E	68	68	78	91	110	130
E2	84	84	96	108	125	140
E3	5	5	6.5	6.5	6.5	6.5
F	100	100	112	127	148	170
G	153	156	175	197	232	264
H	62	62	71	78	94	106
J(h6)	15	15	18	20	24	28
K	24	24	28	30	35	35
L	98.5	98.5	111	122	147	157
L2	103+LR	103+LR	116+LR	127+LR	152+LR	162+LR
L3	48	48	59.8	59.8	73.3	73.3
M	85	85	100	115	130	165
N	70	70	80	95	110	130
O	9	9	9	11	11	13
P	91	91	100	108	129	139.5
Q	70.5	70.5	78	87	107	117.5
R	50	50	56	63.5	74	85
S	M8	M8	M8	M8	M10	M12
T	52	52	58	65.5	76	87
T1	55	55	65	72	79	104
T2	107	107	121	135.5	153	189
U2(h6)	35	35	40	45	50	65
V	60	60	72	80	90	115
W	M8	M8	M8	M10	M10	M12
W2	9	9	9	10	12	14
X	45	50	55	63	75	90
Y	3	3	3.5	3.5	4	4
Z	86	86	86	93	108	108
t1	30	30	35	39.5	44.5	58
b	10	10	12	14	14	16
LA/LB/LC/LR/LM/S	按伺服电机 /By servo motor					

参数符号对应表

SYMBOLS AND UNITS OF MEASURE

符号 Symbols	单位 Units	注解	Description
P	[kW]	功率	Power
P₁	[kW]	输入功率	Transmitted power at input shaft
P₂	[kW]	输出功率	Transmitted power at output shaft
P_{n1}	[kW]	额定输入功率	Rated input power
M₂	Nm	输出扭矩	Transmitted torque at output shaft
M_{e2}	Nm	计算的输出扭矩	Calculated torque at output shaft
M_{n2}	Nm	额定输出扭矩	Rated torque at output shaft
M_{r2}	Nm	需求的扭矩	Required torque at output shaft
n₁	min ⁻¹	输入转速	Angular input speed
n₂	min ⁻¹	输出转速	Angular output speed
i	-	减速比	Ratio
η_d	-	动态效率	Dynamic efficiency
η_s	-	静态效率	Static efficiency
Z₁	-	蜗杆齿数	Number of worm thread
M_x	-	轴向模数	Axial modulus
f_s	-	工作系数	Service factor
J_e	kgm ²	在电机轴上衰减的惯性矩	Moment of the external inertia reduced at the drive shaft
J_m	kgm ²	电机惯性矩	Moment of inertia of motor
F_{r1}	N	输入轴径向负荷	Input shaft radial load
F_{r2}	N	输出轴径向负荷	Output shaft radial load
F_{a2}	N	输出轴轴向负荷	Output shaft axial load



No.789, Shenhua Road, Hangzhou, Zhejiang, China.
Tel: +86-571-88220973 / 88220653
Fax: +86-571-88220651
P.C. 310000

homepage www.hzpt.com
www.ever-power.biz

e-mail hzpt@hzpt.com
webmaster@hzpt.com

